



OBSERVER

Vol. 2014, No. 11

Newsletter of the New Hampshire Astronomical Society

November 2014

In This Issue...

2 [Sky Watch Review](#)

*North Hampton Public Library
Minot-Sleeper Library
Reeds Ferry School
Concord High School
Solar Observing
Heronfield Academy
Salem High School
Crestwood Center
Josiah Carpenter Library*

3 [Society Activities](#)

*Joppa Hill Evening
LTP in the News
South to Northwest
Nashua Winter Stroll*

6 [Object of the Month](#)

December: η Cassiopeiae

7 [Images of the Month](#)

Bubbles Bursting Forth

8 [The Regular Items](#)

*Business Meeting Report
Treasurer's Report
Contact Information
Club Loaner Scopes
Astronomy Resource Guide
Upcoming Events
Credits*

Earth and Moon



Earth and Moon as seen from beyond the farside of the Moon.

(Credit: CNSA)

Many a spacecraft has imaged the Earth-Moon pair from afar, the last specific instance being Cassini from nearly a billion miles away in orbit around Saturn (July 2013). They invariably show the Earth with a small Moon alongside. This is a different, iconic image.

Chang'e 5 is the Chinese lunar exploration program, for which a test flight was launched last month (October 23). Chang'e 5-T1 was not a scientific mission, even though it carried a couple of secondary payloads. Its purpose was to conduct atmospheric re-entry tests at Earth following a free loop around the Moon. On October 28, it took the above image that shows a very large (nearby) Moon and the smaller blue marble Earth 230,000 miles away. Mare Moscoviense is the dark smudge near the center of the lunar terrain, while Crater Tsiolkovskiy can be seen lower left. The Mendeleev basin is about midway between them.

On October 31, after a successful Skip Re-entry procedure, the return capsule of Chang'e 5-T1 landed by parachute in Inner Mongolia and was recovered. The service module of the craft sped on toward the Earth-Moon L2 Lagrangian point, a gravitationally stable point beyond the farside of the Moon from which it could possibly go into Lunar orbit. The precise purpose of this maneuver is not yet known, but in 2012 the Chang'e 2 Lunar Orbiter was sent from the L2 point to encounter the near-Earth asteroid 4179 Toutatis.

The Chang'e program is named after the Chinese Moon Goddess.

North Hampton Public Library, North Hampton NH, November 3

The event took place under hazy, moonlit skies on the backup date. I gave the indoor presentation and the 10 or so library patrons then observed the Moon and other celestial objects through **Bob Veilleux's** SCT.

- **Paul Winalski**

Minot-Sleeper Library, Bristol NH, November 5

There was a crowd of about 25 for the indoor presentation by **Steve Rand**. We set up in a parking lot behind the library. **Gardner Gerry** and **Mark Stowbridge** had also telescopes there and were joined by a couple who were using the library's own Library Telescope. It wasn't very dark as there were several nearby buildings with bright lights. That didn't matter so much because the almost-full Moon was big and bright and it wouldn't have been any darker in any case. I talked to the librarian about having their next skywatch in a darker area; she had some nearby places in mind. I showed the Moon, Albireo and NGC 457; the latter was oriented head-up in my telescope and looked very much like a "Lobster Cluster" that night.

- **John Bishop**

Hello wonderful NHAS people!

On behalf of the Minot-Sleeper Library and its Trustees, we would like to extend a heart-felt thank you for volunteering your time with the Skywatch and the presentation. You guys rock!!! We would love to have you back at our library in the Spring! Next time we will be sure to have hot chocolate and cookies! See you under the stars in the Spring!

*Best always,
Sandy Grutter-Allgood,*

Library Director,
Minot-Sleeper Library,
Bristol, NH 03222

Reeds Ferry School, Merrimack NH, November 10

The event was held under clear but somewhat hazy skies. As usual, there was a big turnout of 200+, with long but patient lines at all the scopes. Among the other NHAS members who showed up with scopes were **Ted Blank, Joe Dechene, Rich DeMidio, Gardner Gerry, John Pappas, Steve Rand** and **Ed Ting**. I set up my 14" TScope and showed NGC 457, the Perseus Double Cluster, M31 and M32, 61 Cygni, Gamma Arietis, and the Pleiades.

- **Paul Winalski**

I spent most of the night on the Double Cluster with the C8 and the 35Pan. The lights of Manchester dimmed the view but lots of folks said "wow" so I guess it wasn't too bad. When it got higher, the view in Paul's scope was amazing.

- **Ted Blank**

Glad to be part of this well-attended and well-supported observing and education event at the Reeds Ferry school in Merrimack. I brought my 14.5" reflector with split-ring mount and showed mainly Neptune and Uranus, with a brief view of Alberio in between.

- **Joe Dechene**

Concord High School Solar Observing, Concord NH, October 9 and November 20

On Thursday October 9, a solar observing session with Concord High School's 60mm Lunt for

H-alpha and my Takahashi FSQ 106mm for white light took place, with excellent conditions for viewing the Sun. A class of 30 got to see two very large sunspot groups and several prominences.

On Thursday November 20, after a couple of postponements, we finally got clear skies for the morning class at Concord High School. Students go to see active region 2214, which is the record-setting sunspot group AR 2192 rotated back into view. It is naked-eye visible and resembles a bear's paw several times the size of the Earth.

- **Paul Winalski**

Heronfield Academy, Hampton Falls NH, November 20

I gave the indoor presentation but, due to a cold, did not participate in the outdoor observing. **Bob Veilleux** and **Ted Blank** were manning the telescopes. About 20 sixth graders were present. One interesting feature of this event is that the students had each assembled one of the Galileo telescope kits and took the scopes out onto the observing field.

Salem High School, Salem NH, November 20

John Bishop, John Pappas and I were in attendance, while NHAS member and teacher **Gary Duranko** gave the talk indoors. About 25 students were in attendance. The Clear Sky Clock predicted clear skies and excellent seeing, but when we set up the clouds were moving in, and soon we were totally soaked in. We tried to show NGC 457, Albireo, the Double Cluster, and M31, but were only partially successful. When the clouds moved in for good, we ended the session.

- **Ed Ting**

Crestwood Center, Milford NH, November 24

Steve Rand gave the presentation and got great reviews – the director said that it was unusual for no one to leave during the presentation! Also in attendance were **Pete Smith**, **Mike Townsend** and myself; we set up scopes indoors for folks to have a look at since there was no outdoor skywatch. On a sad note, we were told that two residents had passed away minutes before we got there, which accounted for the short staff and the sombre mood that night.

- *Ed Ting*



*Steve Rand being introduced, as Pete Smith and some residents look on.
(Photo: Ed Ting)*

Josiah Carpenter Library, Pittsfield NH, November 25

The event was to inaugurate their Library telescope. **Bob Veilleux** gave the indoor presentation, and then the 6 or so people took the library telescope to the observing location. This is an excellent spot on the top of a hill, with almost unobstructed viewing in all directions. There was no artificial lighting. Bob manned the library telescope while I set up my TeleVue 85mm refractor. Conditions were somewhat hazy but still workable. I showed the Pleiades, Alberio, the Perseus Double Cluster and 61 Cygni. Bob found M31 in the library scope. But after about an hour it completely clouded over. This is an excellent observing site and I hope we're asked back when the sky conditions are better.

- *Paul Winalski*

Society Activities

Joppa Hill Farms, Bedford NH, November 15

It was not quite a Flash Mob that congregated in Bedford on a clear, crisp evening on the Ides of November. But when **Ed Ting** issues an impromptu 6pm invitation on the Chat mailing list, it is well worth answering the call. His report on the proceedings:

John Rose, Pat Adams, Don and Melinde Byrne and I went to Joppa Hill. It was clear but cold. I brought a C9.25 and a Sirius mount and John brought an old NexStar 5 he'd just bought off Craigslist. It was cold, so we didn't stay long - maybe 45 minutes. I used the Goto on the Sirius and we saw M13, M27, M31, M15 and M92. It was cold, so we packed up early. Did I mention, it was cold?

LTP in the News (again), Concord NH, November 18

Rob Mack is the “foster parent” of the *Concord Public Library telescope* (the mighty 100th), and he took part in the presentation ceremony on September 24 ([check the Observer, page 9](#)). The event was also covered as a [news item](#) by **Tim Goodwin** of *The Concord Insider*. Naturally the next logical step taken by Tim has been to write [his own article about the Library Telescope Program and NHAS, now available online... click for a good read](#). Thanks Rob, for the information!

April South to Northwest

*[Over the past 3 years **April South** has been known for more than just two exceptional skills – bringing the best cookies to a gathering, and the ability to fold the NHAS Tent into a shoe-box and deliver it wherever it is needed. We wish her all the best with her move to Portland, Oregon. She will be missed! Although... it can be seen as a simple horizontal flip from Northeast to Northwest; owning a Takahashi FS-78 can do that to a person's FOV. -Ed.]*

Thank you for the opportunity to be part of such a wonderful organization. Although various health problems have prevented me from attending more events this year, I am so pleased to have experienced all that I have with NHAS.

I have looked back through my personal calendar and noted all the activities I got to participate in as a result of being an NHAS member, and it has impressed me. This club is one of the most dynamic and enriching organizations I have had the pleasure and privilege to be a part of. Even the regular business meetings were a treat to attend with the guest speakers and great discussions. I always walked away having learned something new. Among my NHAS Experiences:

First NHAS skywatch – March 2012. Ed Ting was the speaker at Amherst. I was inspired by all the members and their scopes to join NHAS.

My first real telescope purchase – April 2012. Orion XTi10. My selection was due to Pete Smith and his great scope.

YFOS orientation and workshops – April 2012. YFOS is an impressive site and I have enjoyed all the workshops there.

Transit of Venus – June 2012. My first real disappointment with New England weather. Great presentation and the guest speaker at the May business meeting motivated me to make a solar filter and sun funnel. The clouds, however, had a different idea.

Mt. Megantic Observatory Astronomy Festival – July 2012. Great time with NHAS members and ASNNE in Canada observing in an International Dark Sky Reserve.

Spring Messier Marathon – March 2013. Up all night with club members enjoying clear skies, good food and great conversation.

LTP mod party – February and March 2013. I learned how to take apart a telescope and reassemble it without breaking it, although I almost dropped a primary mirror once. Became Foster parent to the Hollis Library telescope.

Aerospace Fest @ MSDC – June 2013. I learned to assemble the canopy and had the opportunity to help with solar viewing in the Observatory.

Stellafane – August 2013. A great weekend of camping, learning, observing and the fantastic NHAS cookout!

NEFAF – September 2013. Helped with the children's Lunar Clock table and the Van Allen Probe table. One of the highlights of the day was meeting Dava Sobel.

I wish you all continued success with your outreach and in-reach programs. You provide such a valuable service to the members and the wider community. Best wishes and clear skies to you all!

- *April South*

Nashua Winter Stroll, Nashua NH, November 29

Ken Charles organized the troops for the annual post-Thanksgiving event at Bicentennial Park in downtown Nashua. Other NHAS members with scopes and GLPs were **Joe Dechene, Joe Derek, Gardner Gerry, “Rags” Gilmore, Rich and Susan Schueller, Ed Ting** and **Mike Townsend**. A heavy pre-Thanksgiving snowstorm caused power outages in the area, but did not appear to affect the turnout or the enthusiasm at the skywatch. It was a bit cloudy and to quote Ed Ting once again: *it was cold.*



Luna observed and admired, with Gardner’s assistance. (All Photos by Ed Ting, except as noted)



Another look at the Moon, with the club loaner Coulter dob. As a member, she could have taken it home on loan! (Photo: “Rags”)



Mike Townsend offering a cool look at, what else, the Moon (with his C102F), generating excitement for young and old alike all night.



Ken Comfortable, master of ceremonies, with Soulshine.



Gardner Gregarious, with lots of company around his C9.25 on G11.



Just about everyone queued up for a look through Joe Derek’s 12.5” Newtonian, including someone looking remarkably like Joe himself!

Gardner Gerry adds:

All we had to show off was the Moon, except for Mike with his Short Tube on the Pleiades. Joe Dechene had his home-built reflector on the Double Double and maybe other targets as well. We were busy all night long until the clouds rolled in at about 9:30pm, which was a blessing in disguise so that we could break down and get out of there when they opened Main Street to traffic. A big thanks to Rich and Sue for bringing hot chocolate!

It was cold.

Eta (η) Cassiopeiae – Double Star in Cassiopeia

by Glenn Chaple

The spotlight this month goes to the binary star **Struve 60** [Σ 60], better known as **eta (η) Cassiopeiae** (or *Achird*, if you prefer its Arabic name). But first, some details.

William Herschel discovered the duplicity of eta Cassiopeiae in 1779. At the time, the magnitude 7.4 companion was 11.3 arc-seconds east-northeast (position angle 62°) of the magnitude 3.5 primary. Since then, it has traveled three-quarters of the way around the main star to its current location $13.2''$ to its northwest (P. A. of 323°). A complete orbit takes about 480 years. Eta Cas A is a main sequence G0-type star – a virtual twin of our Sun, similar in mass and size. Eta Cas B is an M0-type star with about 2/3rds the Sun's mass and size. The pair lies 19.4 light years away.

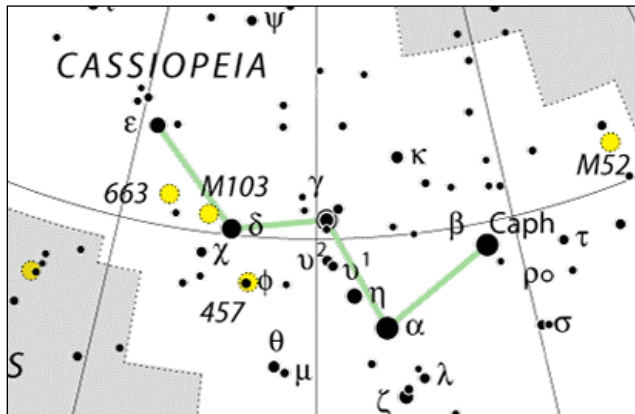

(Skychart courtesy: *Sky & Telescope*)

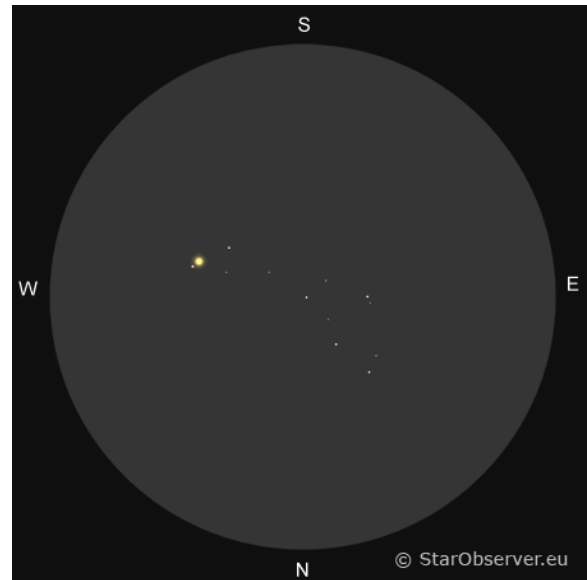

(Sketch courtesy: www.starobserver.eu,
[click for more details and a look at Herschel's notes](#))

Now for the neat stuff. Eta Cas sports a color contrast so stunning that **James Mullaney** and **Wallace McCall** included it in their 1960s *Sky and Telescope* series "*The Finest Deep-Sky Objects.*" I have no reason to argue the selection. After viewing eta Cas with a 90 mm f/11 refractor at 167X, I wrote: "Striking colors! Primary golden yellow; companion pale red." **Sissy Haas**, in her book *Double Stars for Small Telescopes*, considers it a showcase pair. Check it out and see if you agree.

Before putting your telescope away, stand back and take a good naked eye look at eta Cas and its neighbor gamma (γ) Cas. Visually a magnitude brighter than eta Cas, gamma appears to be much closer. It's an illusion. Gamma Cas is actually nearly 30 times farther away. Move this blue-white sub-giant next to eta Cas, and it would shine at a dazzling magnitude -5.5 . Remember, eta Cas is a twin to the Sun. If it (or our Sun) were moved to the same distance as gamma Cas, it would be a 12th magnitude speck.

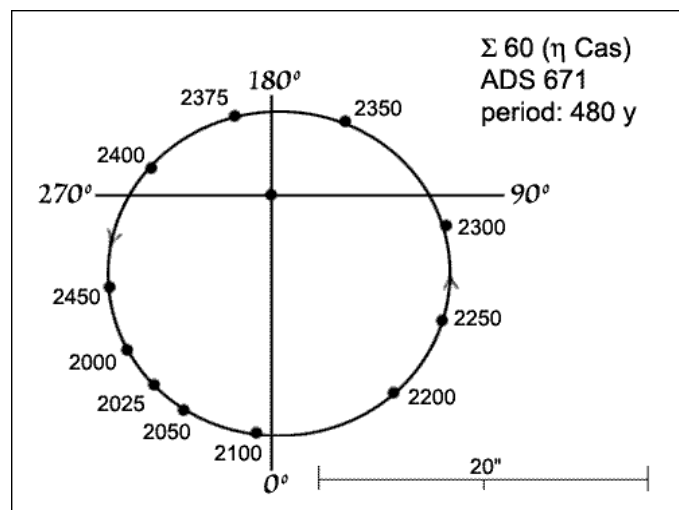

(Chart courtesy: **Richard Dibon-Smith** www.dibonsmith.com)

Bubbles Bursting Forth



Inspired by Gardner Gerry's example ([in September](#)), both Herb Bubert (above) and Gary Duranko (below) have gone after the Bubble Nebula. Herb did some more PixInsight processing, whereas in the Gary's case, the M52 cluster alongside proved irresistible, almost pushing the Bubble off-frame. They do tend to float!



NHAS November 2014 Business Meeting Report

The monthly business meeting was held at St. Anselm College, Manchester NH on November 14th, with our President **Ted Blank** presiding. The Treasurer's report by "**Rags**" follows on the next page.

President's Report

The NHAS **Observer** was the lead item, featuring last month's Page 1 and the *LMC*. Members were invited to help the club newsletter by sending in articles, anecdotes, ideas and pictures to [Ramaswamy](#). The calendar from the newsletter was also used to list upcoming club outreach events.

Both First Friday and the Portsmouth Sidewalk Astronomy sessions were clouded out recently, but "**Rags**" conducted a good dark skies event at the Rey Center. NEFAF 2014 was reviewed with a pictures slide show of the many NHAS participants.

An upcoming noteworthy event is the occultation of a mag 7.0 star by the asteroid 3 *Juno* on Nov. 20 at 1:56am, with the track running mostly over Maine. Volunteers from area clubs are being sought to operate 6 recording scopes that will be positioned around the state by **Paul Maley** of IOTA.

The Top 3 News items of the past month fused into one this time:

* [Rosetta's Philae lander set down on Comet 67P/Churyumov-Gerasimenko in dramatic fashion](#) on Wednesday, November 12 at about 1535 UT, with its signal reaching ESA Control Center in Darmstadt, Germany at 1603 UT.

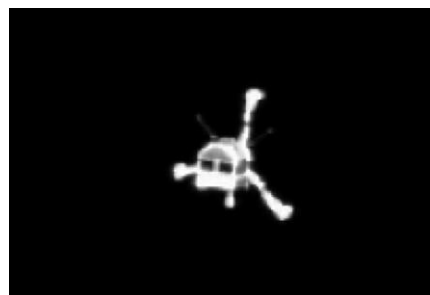

Philae on the way down from Rosetta.
(Credit: ESA)

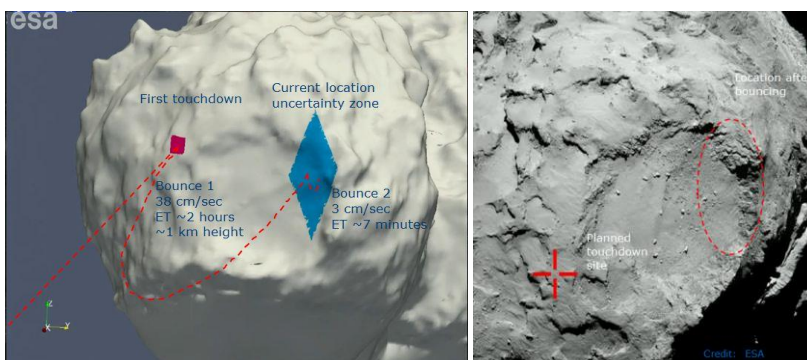

The double bounce of the Philae landing, indicating possible final resting spot.
(Credit: ESA, with supplementary annotations by Ted Blank)

John Shonle recently sold off a lot of his "excess" astronomy gear and donated the proceeds to the club. His check was for \$3105! He had some more gear for sale at the meeting: video camera, Sky Scout.

Ted Blank circulated a framed commendation for NHAS from **Governor Lynch** (2 years ago).

Website update

Matt Marulla presented the all-new-improved page of [the online "Join NHAS" form](#) for new and renewing members; it also handles magazine subscriptions. There is also an option to get a printable PDF form. When filled in, the form redirects one to PayPal for the payment. It also generates emails to the Treasurer and Membership chair on a successful transaction.

The 2015 Elections

The following names were placed in nomination and seconded:
President: **John Bishop**
Vice President: **Tom Cocchiaro**
Secretary: **Paul Winalski**
Treasurer: **David Gilmore**
Director: **Steve Rand**

Astronomy Shorts

Bob Veilleux: showed off a piece of the iron meteorite that blazed over the Sikhote-Alin mountains of eastern Siberia on Feb. 12, 1947.

Rich Schueller: caught the Total Lunar Eclipse in Hawaii with Susan, poolside, on their anniversary.

Ken Charles: needs 6-8 telescopes at Bicentennial Park in Nashua for the Winter Stroll on Nov. 29.

The Evening Presentation

John Gianforte, Astronomer, Science writer, and better known locally as the "Sky Guy," has been conducting research on Cataclysmic Variable stars (CVs) and transiting extrasolar planets. Tonight he talked about a newly emerging field that is well within the reach of amateur astronomers: "**How to observe transits of extrasolar planets using small aperture telescopes.**" Each week as more extrasolar planets are being discovered, there are just not enough telescopes to conduct the necessary follow-up research to predict future transits and study these new worlds. You can help!

NHAS Treasurer's Report
(as of November 14, 2014)

| | | | | |
|-----------------------------------|--------------------|-------------------------|-----------------|------------------------|
| Starting Checking Balance: | \$9,917.68 | Membership: | 40 | |
| Deposits: | | | | Single + Family |
| Membership | 412.98 | Cash Renewals: | 8x30.00+0x10.00 | 240.00 |
| Donations | 170.00 | Cash New Members | 0x30.00+0x10.00 | 0.00 |
| Interest | 0.46 | PayPal Renewals: | 6x28.83+0x 9.61 | 172.98 |
| Total: | \$583.44 | PayPal New Members: | 0x28.83+0x 9.61 | 0.00 |
| Expenses Paid: | | Total: | 14 | \$412.98 |
| Rackspace Cloud (Web site) | 22.69 | Current Members: | 54 | |
| Rhymes Propane | 110.41 | New Members: | | |
| Total: | \$133.10 | [none] | | |
| Current Checking Balance: | \$10,368.02 | Donations: | | |
| Petty Cash: | \$100.00 | Larry Daddario | EOC | 100.00 |
| Current Cash Balance: | \$10,468.02 | Eugene Solod | GEN | 70.00 |
| EOC Share: | \$6,367.02 | Total: | | \$170.00 |

Contact Information

| | |
|---|--|
| <p><u>How to join NHAS</u></p> <p>Write to us: NHAS P. O. Box 5823 Manchester, NH 03108-5823</p> <p>Send Email to: info@nhastro.com</p> <p>Visit our web site: http://www.nhastro.com</p> <p><u>How to contribute to the Observer</u></p> <p>Email articles and snapshots to the Editor: ramax.astro@yahoo.com</p> | <p>NHAS Officers:</p> <p>President: Ted Blank Vice-President: Tom Cocchiaro Secretary: Paul Winalski Treasurer: David "Rags" Gilmore</p> <p>Board of Directors:</p> <p>Ken Charles Pete Smith Steve Rand</p> |
|---|--|



**Orion Starblast 4.5 –
LTP-style Scope**

Custodian: Pete Smith
Contact: psastro60@gmail.com

Equipped with:

Commercial red-dot finder with a special Joel Harris mount.
Celestron 8mm-24mm zoom EP, plus 17mm and 6mm EPs.
Instruction booklet and an Audubon constellations guide.
A red/white Headlamp and a Lens Cleaning Pen in the pouch.
A simple Collimation Cap to learn to collimate the old way.
A Planisphere and a Moon Map.
Richard Berry's "Discover the Stars"

How to Borrow a Loaner Scope in 3 Simple Steps

- Contact the custodian of scope you're interested in
- Arrange to meet for the transfer (usually at a monthly Business Meeting)
- Sign the requisite papers and leave with the scope

It is a benefit of your membership in NHAS. The loan will be for 2 months; an extension might be granted if no one else is waiting for the unit. The objective is to help new members get to know what will suit them personally, to experiment with options and to understand **what will work** in the time available to them to pursue their new hobby, and equally, **what may not**. A suitable (beginner's) telescope is invariably one that is easy to transport to the observing site and easy to setup, and not necessarily the one with the most aperture or sophistication.



**Orion XT6 – 6" Newtonian
on a Dobson mount**

Custodian: Ted Blank
Contact: tedblank@gmail.com

Equipped with:

Telrad finder with a dew shield
32mm, 25mm & 10mm Plössl
EPs in a case
A Planisphere, a Moon map
and a red light
Orion XT6 user manual
Richard Berry's
"Discover the Stars"

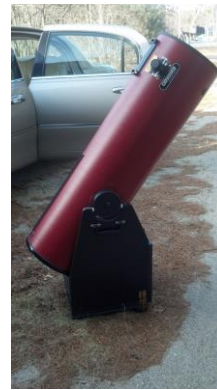

**Coulter Odyssey 10" Newtonian
on a Dobson mount**

Custodian: "Rags" Gilmore
Contact: nhas@ragnorok.net

Equipped with:

Telrad finder with a dew shield
26mm TeleVue Plössl and
15mm Celestron Plössl in a case
A Planisphere and a Moon map
Richard Berry's "Discover the Stars"

*Also available, independently of the
telescope and in a separate slip-case:*

Sky Atlas 2000.0 by Wil Tirion and Roger Sinnott
Sky Atlas 2000.0 Companion: Robert Strong & Roger Sinnott



**Meade 8" Newtonian
on a Dobson mount**

Custodian: Ken Charles
Contact: starnek2550@gmail.com

Equipped with:

Telrad finder with a dew shield
25mm and 10mm EPs
A custom-built base (made by
Joe Derek and Chase McNiss)



**Orion XT10 Newtonian
on a Dobson mount**

Custodian: Pete Smith
Contact: psastro60@gmail.com

Equipped with:

Telrad finder
Assorted EPs: 35mm, 25mm
wide-angle, 17mm and
a mystery one (25mm?).
An EP case
Richard Berry's
"Discover the Stars"

Regional Astronomy Clubs

New Hampshire Astronomical Society
[NHAS] *Skywatches around the State*
Sidewalk Astronomy in Portsmouth
www.nhastro.com

Amateur Astronomical Society of Rhode Island (North Scituate, RI)
www.theskyscrapers.org

Amateur Telescope Makers of Boston
(Westford, Mass.)
www.atmob.org

Astronomy Society of Northern New England (Kennebunk, Maine)
www.asne.org

Gloucester Area Astronomy Club
(Gloucester, Mass.)
www.gaac.us

McAuliffe-Shepard Discovery Center [MSDC] (Concord, NH)
First Friday Observing Event
www.starhop.com

Northeast Kingdom Astronomy Foundation (Peacham, VT)
www.nkaf.org

North Shore Astronomy Club
(Groveland, Mass.)
www.nsaac.org

Penobscot Valley Star Gazers
(Bangor, Maine)
www.gazers.org

Online Live Observatories

Astronomy Live (broadcasts)
www.astronomylive.com

SLOOH (Tenerife, Canary Is.)
www.slooh.com/about.php

Worldwide Telescope
www.worldwidetelescope.org

Magazines

Astronomy
www.astronomy.com

Sky & Telescope
www.skyandtelescope.com

Astronomy Gear

Adorama
www.adorama.com

Agena AstroProducts
www.agenaaastro.com

Astromart
(Used equipment and advice)
www.astromart.com

Astronomy-Shoppe
(in Plaistow, NH 03865)
www.astronomy-shoppe.com

Celestron
www.celestron.com

Cloudynights
(Used equipment, Articles, Forums and Reviews)
www.cloudynights.com

Explore Scientific
www.explorescientific.com

High Point Scientific
www.highpointscientific.com

Kendrick Astro Instruments
www.kendrickastro.com

Lunt Solar Systems
www.luntsolarsystems.com

Meade Instruments
www.meade.com

Oceanside Photo & Telescope
www.optcorp.com

Orion Telescopes
www.telescope.com

ScopeStuff
www.scopestuff.com

TeleVue
www.televue.com

Vixen Optics
www.vixenoptics.com

William Optics
www.williamoptics.com

Astronomy Web Sites

CalSky
(Sky Calendar to plan Observing)
www.calsky.com

Free Star Charts
(Star Charts for MM, Planets etc.)
www.freestarcharts.com

Heavens Above
(on Satellites, Spacecraft, Planets)
www.heavens-above.com

NASA
www.nasa.gov

Dark skies Observing Sites
(Horizons and Clear Sky information)
www.observingsites.com

ScopeReviews
(Reviews by Ed Ting, NHAS)
www.scopereviews.com

Sloan Digital Sky Survey DR10
<http://skyserver.sdss3.org/>

SpaceWeather
(Solar activity, Asteroid passes)
www.spaceweather.com

Computer Software

Cartes du Ciel (*aka Skychart*) (Free)
www.ap-i.net/skychart/

Celestia
www.shatters.net/celestia

Computer Aided Astronomy (Free)
www.astrosurf.com/c2a/english/

Earth Sky Tonight
www.earthsky.org/tonight

SkyMap Online
www.skymaponline.net









Starry Night
(many versions, Novice to Expert)
www.starrynight.com

Stellarium (Free)
www.stellarium.org

WinStars (Free)
www.winstars.net/english/

| Event | Date | Time | Location |
|---|-------------------------|--------|--|
| Blaisdell Memorial Library (Library Telescope Training) | Monday, December 1 | 7:00pm | 129 Stage Rd, Nottingham, NH |
| Epping Middle School Skywatch | Wednesday, December 3 | 7:00pm | 33 Prescott Road, Epping NH |
| Skywatch for Cub Scout Pack 405 | Thursday, 4 December | 6:30pm | 47 E Derry Rd, Derry, NH |
| First Friday Skywatch for MSDC | Friday, December 5 | 7:00pm | MSDC, Concord NH |
| Skywatch for Bedford High School | Monday, December 8 | 7:00pm | Benedictine Park, Bedford NH |
| Skywatch for Bedford High School (backup date) | Tuesday, December 9 | 7:00pm | Benedictine Park, Bedford NH |
| EOC Meeting | Thursday, December 11 | 6:30pm | Manchester City Library, Manchester NH |
| Concord High School Skywatch | Thursday, December 11 | 7:00pm | White Farm, Rt. 13, Concord NH |
| NHAS Business Meeting (Election and Pot-Luck) | Friday, December 12 | 7:30pm | MSDC, Concord NH |
| Skywatch for Parkside Middle School | Monday, December 15 | 6:30pm | 75 Parkside Avenue, Manchester NH |
| Skywatch for Parkside Middle School (backup date) | Thursday, December 18 | 6:30pm | 75 Parkside Avenue, Manchester NH |
| Coffee House Night at YFOS | Saturday, December 20 | 5:00pm | YFOS |
| Rey Center Skywatch | Saturday, December 20 | 6:30pm | Waterville Valley NH |
| Nesmith Library Skywatch | Monday, December 22 | 6:00pm | 8 Fellows Rd, Windham NH |
| Sidewalk Astronomy Skywatch | Saturday, December 27 | 6:00pm | Market Square, Portsmouth NH |
| Nesmith Library Skywatch (first backup date) | Monday, December 29 | 6:00pm | 8 Fellows Rd, Windham NH |
| Nesmith Library Skywatch (second backup date) | Tuesday, December 30 | 6:00pm | 8 Fellows Rd, Windham NH |
| Portsmouth First Night Skywatch | Wednesday, December 31 | 6:00pm | Market Square, Portsmouth NH |
| Happy New Year! | | | |
| First Friday Skywatch for MSDC | Friday, January 2 | 7:00pm | MSDC, Concord NH |
| EOC Meeting | Thursday, January 8 (?) | 6:30pm | Manchester City Library, Manchester NH |
| NHAS Business Meeting | Friday, January 9 | 7:30pm | St. Anselm College, Manchester NH |
| Skywatch for Mary E. Bartlett Library | Thursday, January 15 | 7:00pm | 22 Dalton Road, Brentwood NH |
| Skywatch for Gilmanton School | Friday, January 16 | 6:30pm | 1386 NH Route 140, Gilmanton NH |
| Coffee House Night at YFOS | Saturday, January 17 | 5:00pm | YFOS |
| Skywatch for Gilmanton School (backup date) | Friday, January 23 | 6:30pm | 1386 NH Route 140, Gilmanton NH |
| Rey Center Skywatch | Saturday, January 24 | 6:30pm | Waterville Valley NH |
| Skywatch for Mary E. Bartlett Library (first backup date) | Thursday, January 29 | 7:00pm | 22 Dalton Road, Brentwood NH |
| Skywatch for Mary E. Bartlett Library (second backup date) | Friday, January 30 | 7:00pm | 22 Dalton Road, Brentwood NH |

Note: Please check [\[Calendar\]](#) at www.nhastro.com for up-to-date information on upcoming events.

| Date | Lunar Phase |
|----------------------|--|
| Saturday, December 6 |  Full moon 12:27pm |
| Sunday, December 14 |  Last quarter 12:51pm |
| Monday, December 22 |  New moon 1:36am |
| Sunday, December 28 |  First quarter 6:31pm |
| Monday, January 5 |  Full moon 4:53am |
| Tuesday, January 13 |  Last quarter 9:47am |
| Tuesday, January 20 |  New moon 1:14pm |
| Tuesday, January 27 |  First quarter 4:48am |

Credits

Contributors to this month's **Observer:**

John Bishop, Ted Blank, Herb Bubert, *Glenn Chaple*, Joe Dechene, Gary Duranko, Gardner Gerry, *John Gianforte*, "Rags" Gilmore, Rob Mack, Matt Marulla, Steve Rand, John Rose, Pete Smith, April South, Ed Ting, Mike Townsend, Bob Veilleux and Paul Winalski.